

## General Description

TD2786 is a 3A synchronous buck converter with integrated power MOSFETs. The TD2786 design with a current-mode control scheme, can convert wide input voltage of 4.5V to 30V to the output voltage adjustable from 0.92V to 28V to provide excellent output voltage regulation.

The TD2786 is equipped with an automatic PFM/PWM mode operation. At light load, the IC operates in the PFM mode to reduce the switching losses. At heavy load, the IC works in PWM mode.

The TD2786 is also equipped with Power-on-reset, soft- start, and whole protections (over-temperature, and current-limit) into a single package.

This device, available ESOP-8, provides a very compact system solution external components and PCB area.

## Features

- Wide Input Voltage from 4.5V to 30V
- 3A Continuous Output Current
- Adjustable Output Voltage from 0.92V to 28V
- Integrated N-MOSFET
- Fixed 340kHz Switching Frequency
- PFM/PWM mode Operation
- Stable with Low ESR Capacitors
- Power-On-Reset Detection
- Programmable Soft-Start
- Over-Temperature Protection
- Over-Voltage Protection
- Current-Limit Protection with Frequency Foldback
- Enable/Shutdown Function
- Lead Free and Green Devices Available(RoHS Compliant)

## Applications

- Distributed Power Systems
- Networking Systems
- FPGA, DSP, ASIC Power Supplies
- Green Electronics/ Appliances
- Notebook Computers

## Pin Configurations

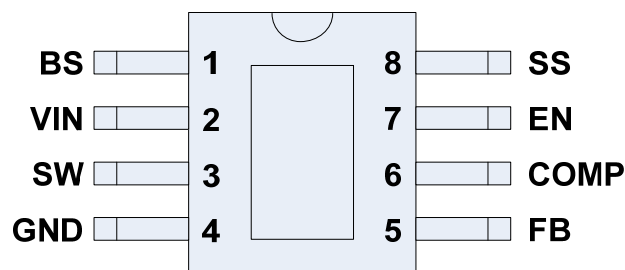
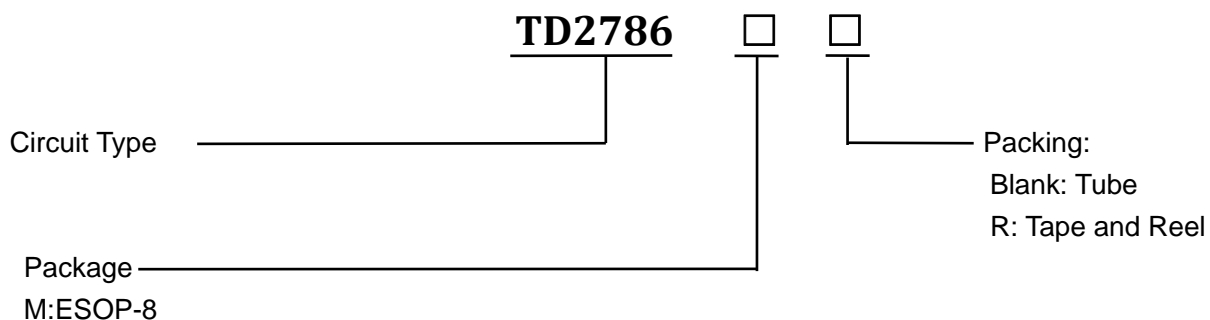

Figure1 Pin Configuration of TD2786(Top View)

### Pin Description

Pin Number	Pin Name	Description
1	BS	High-Side Gate Drive Boost Input. BS supplies the voltage to drive the high-side N-channel MOSFET. At least 10nF capacitor should be connected from SW to BS to supply the high side switch.
2	VIN	Power Input. VIN supplies the power (4.5V to 30V) to the control circuitry, gate drivers and step-down converter switches. Connecting a ceramic bypass capacitor and a suitably large capacitor between VIN and GND eliminates switching noise and voltage ripple on the input to the IC.
3	SW	Power Switching Output. SW is the Drain of the N-Channel power MOSFET to supply power to the output LC filter.
4	GND	Ground.
5	FB	Output feedback Input. The TD2786 senses the feedback voltage via FB and regulates the voltage at 0.92V. Connecting FB with a resistor-divider from the converter's output sets the output voltage from 0.92V to 28V.
6	COMP	Output of the error amplifier. Connect a series RC network from COMP to GND to compensate the regulation control loop. In some cases, an additional capacitor from COMP to GND is required.
7	EN	Enable Input. EN is a digital input that turns the regulator on or off. Pull up with 100k resistor for automatic startup.
8	SS	Soft-Start Control Input. SS controls the soft-start period. Connect a capacitor from SS to GND to set the soft-start period. A 0.1µF capacitor sets the soft-start period to 15ms. To disable the soft-start feature, leave SS unconnected.

### Ordering Information



Function Block

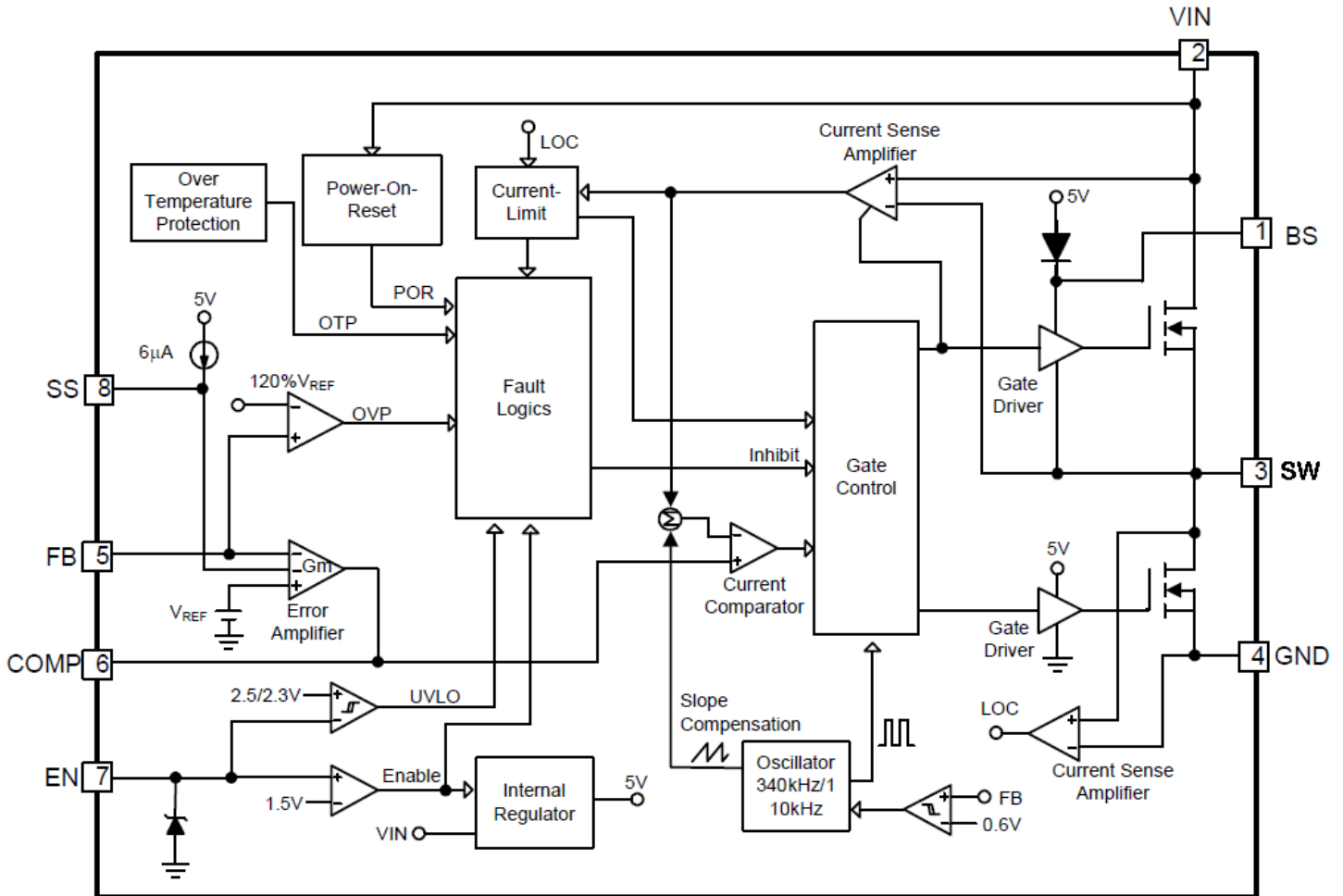

Figure 2 Function Block Diagram of TD2786

Absolute Maximum Ratings

Parameter	symbol	Value	Unit
Input Voltage	V <sub>IN</sub>	-0.3 to 32	V
SW Pin GND Voltage	V <sub>SW</sub>	-0.3 to V <sub>IN</sub> +0.3	V
EN,FB,COMP,SS to GND Voltage		-0.3 to 6	V
BS to GND Voltage	V <sub>BS</sub>	V <sub>SW</sub> -0.3 to V <sub>SW</sub> +6	V
Power Dissipation	P <sub>D</sub>	Internally limited	mW
Operating Junction Temperature	T <sub>J</sub>	150	°C
Storage Temperature	T <sub>STG</sub>	-65 to 150	°C
Lead Temperature	T <sub>LEAD</sub>	260	°C

## 3A 30V Synchronous Rectified Step-Down Converter

TD2786

ESD (HBM)		2000	V
MSL		Level3	
Junction to Ambient Resistance in Free Air	$\theta_{JA}$	50	°C/W
Junction to Case Resistance in Free Air	$\theta_{JC}$	10	°C/W

## Recommended Operating Conditions

Parameter	Symbol	Min.	Max.	Unit
Input voltage	$V_{IN}$	4.5	30	V
Output voltage	$V_{out}$	0.925	28	V
Converter output current	$I_{out}$	0	3	A
Operating junction temperature	$T_J$	-40	125	°C
Operating ambient temperature	$T_A$	-40	85	°C

## Electrical Characteristics

$V_{IN}=12V$ ,  $V_{out}=3.3V$ ,  $V_{EN}=3V$ ,  $T_A=+25^\circ C$ , unless otherwise noted

Parameter	Symbol	Condition	Min	Typ	Max	Units
<b>SUPPLY CURRENT</b>						
VIN Supply Current	$I_{VIN}$	$V_{FB}=1V$ , $V_{EN}=3V$ , $SW=NC$	-	1.9	-	mA
VIN Shutdown Supply Current	$I_{VIN\_SD}$	$V_{EN}=0V$	-	0.3	-	uA
<b>POWER-ON-RESET (POR)</b>						
VIN POR Voltage Threshold		$V_{IN}$ Rising	3.8	4.1	4.4	V
VIN POR Hysteresis			-	0.3	-	V
<b>REFERENCE VOLTAGE</b>						
Reference Voltage	$V_{REF}$	Regulated on FB pin	0.9	0.92	0.946	V
<b>OSCILLATOR AND DUTY CYCLE</b>						
Oscillator Frequency	$F_{OSC}$		300	340	380	kHz
Foldback Frequency		$V_{FB}=0V$	-	110	-	kHz
Maximum Converter's Duty			-	90	-	%
Minimum On Time			-	220	-	ns
<b>PFM MODE OPERATION</b>						
PFM Mode Current Limit	$I_{PK\_PFM}$		-	0.8	-	A
PWM to PFM Inductor Peak Threshold	$I_{PK\_TH}$		-	0.6	-	A
<b>POWER MOSFET</b>						
High/low Side MOSFET On Resistance			-	110	-	mΩ
High/Low Side MOSFET Leakage Current		$V_{EN}=0V$ , $V_{LX}=0V$	-	-	10	uA

3A 30V Synchronous Rectified Step-Down Converter

TD2786

CURRENT-MODE PWM CONVERTER						
Error Amplifier Transconductance	G <sub>m</sub>		-	820	-	uA/V
Error Amplifier Voltage Gain		COMP=NC	-	80	-	V/V
Switch Current to COMP Voltage Transconductance			-	5.2	-	A/V
PROTECTIONS						
High Side MOSFET Current-Limit	I <sub>LIM</sub>	Peak Current	-	5.6	-	A
Over-Temperature Trip Point	T <sub>OTP</sub>		-	160	-	°C
Over-Temperature Hysteresis			-	50	-	°C
Over-Voltage Protection			-	120	-	%
SOFT-START, ENABLE AND INPUT CURRENTS						
Soft-Start Current			-	6	-	uA
EN Enable Threshold Voltage		V <sub>IN</sub> =4.5~28V	0.4	-	2	V
EN Under-Voltage Lockout (UVLO) Threshold			2.3	2.5	2.7	V
EN UVLO Hysteresis		V <sub>EN</sub> rising	-	200	-	mV

Typical Application Circuit

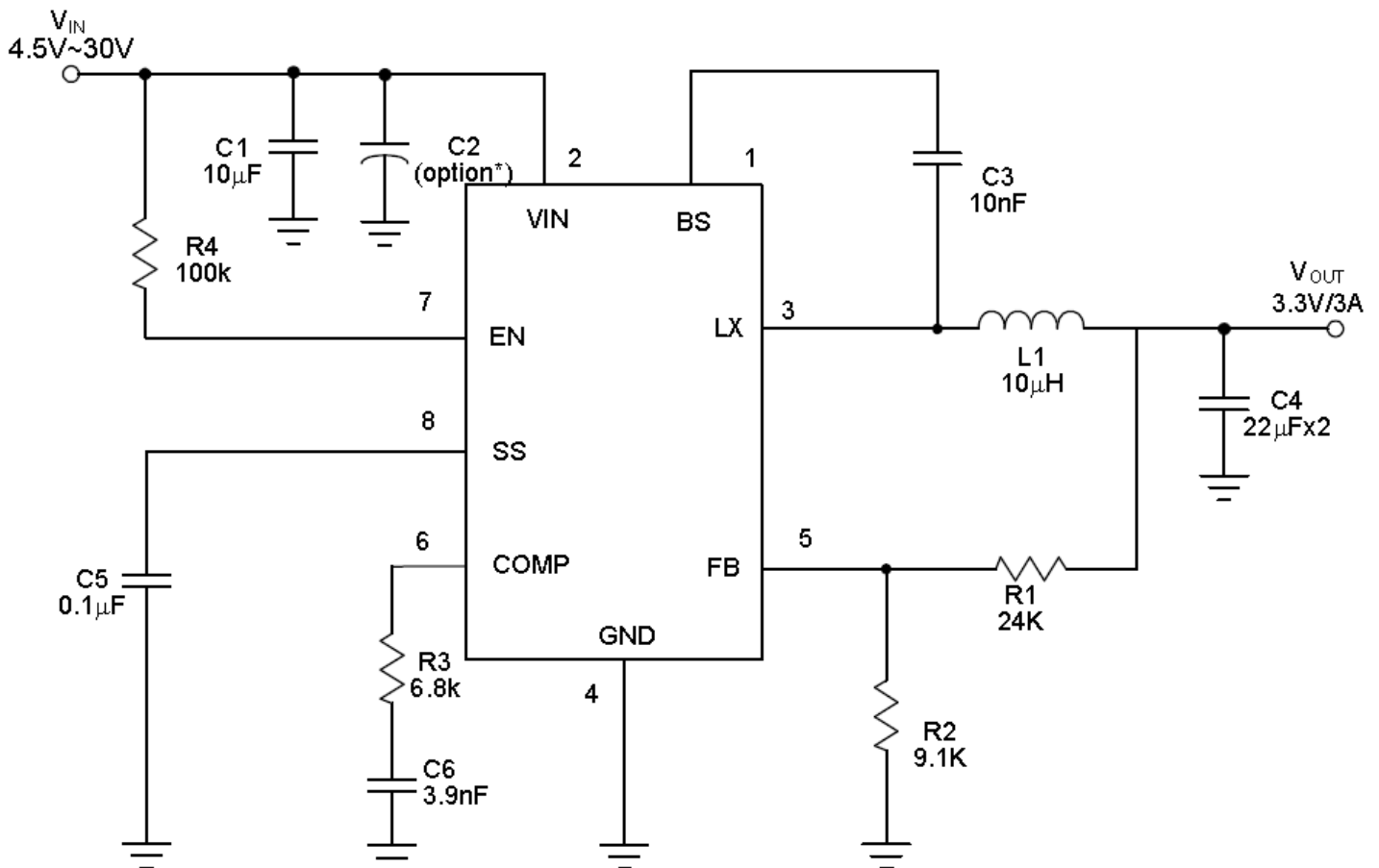

\* For critical condition, like plug in, the large capacitance and high voltage rating are needed to avoid the high spike voltage.

Recommended Feedback Compensation Value

Vin(V)	Vout(V)	L1(µH)	C2(µF)	R1(KΩ)	R2(KΩ)	R3(KΩ)	C5(nF)
24	5	10	22(Ceremic)	39	9.1	6.8	3.9
12	5	10	44 (Ceremic)	39	9.1	5	1.5
12	3.3	10	22 (Ceremic)	24	9.1	6.8	3.9
12	2.5	10	22 (Ceremic)	15	9.1	6.8	3.9

### Typical Performance Characteristics

Refer to the "Typical Application Circuit" The test conditions are  $V_{IN}=12V$ ,  $V_{OUT}=3.3V$ ,  $L_1=10mH$ ,  $C_2=22mF$ ,  $T_A=25^\circ C$  unless otherwise specified.

Efficiency vs. Output Current

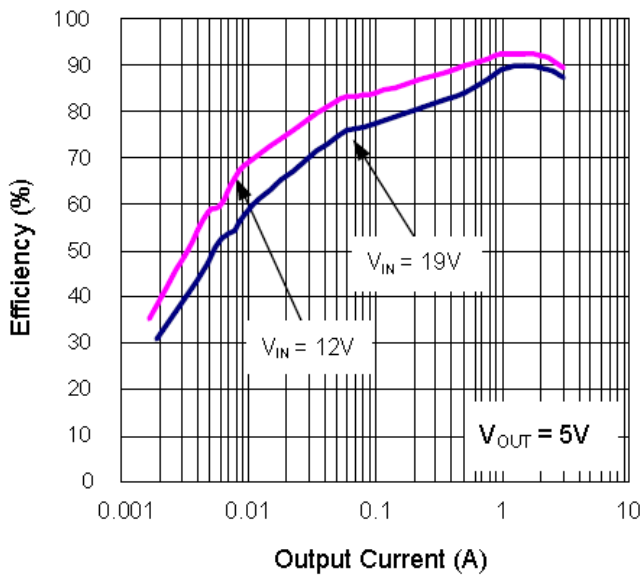

Efficiency vs. Output Current

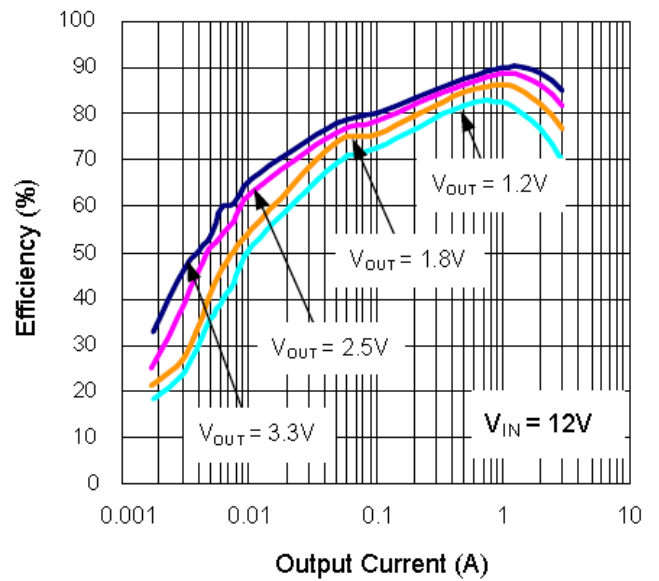

VIN Supply Current vs. VIN Supply Voltage

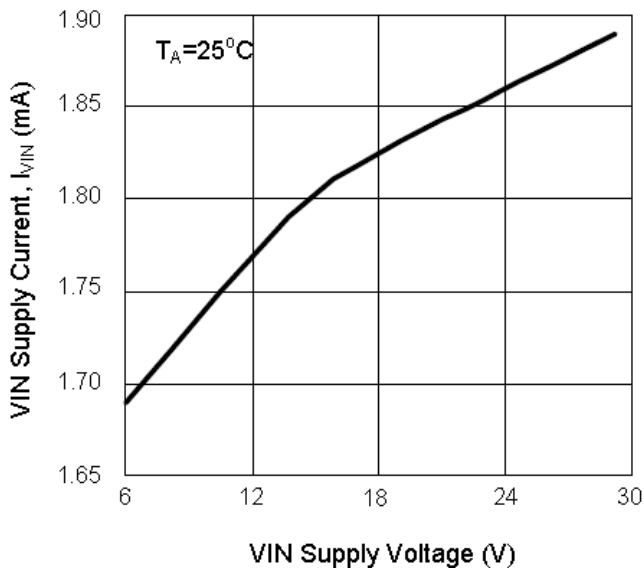

Soft Start Time vs. SS pin to GND Capacitance

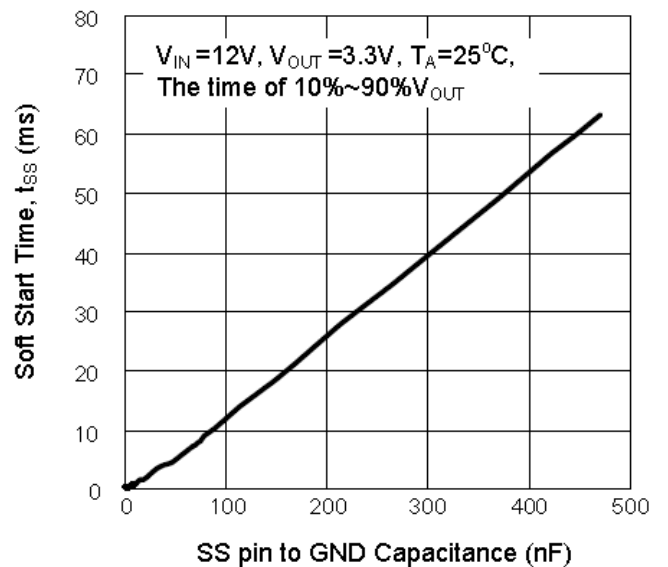

**EN UVLO Threshold Voltage vs. VIN Supply Voltage**

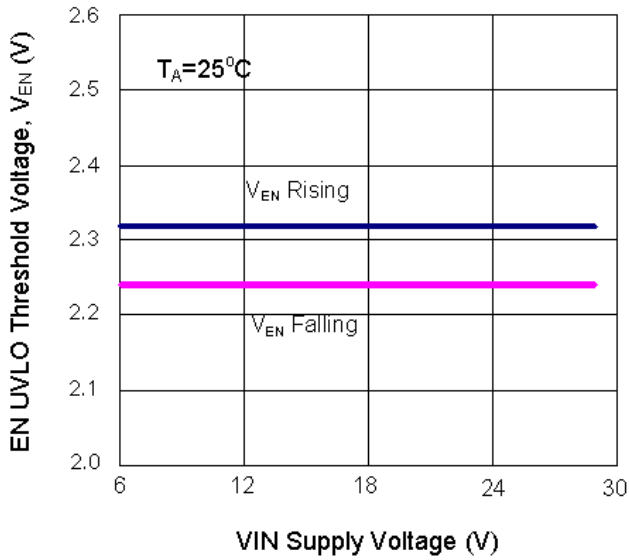

**Reference Voltage vs. VIN Supply Voltage**

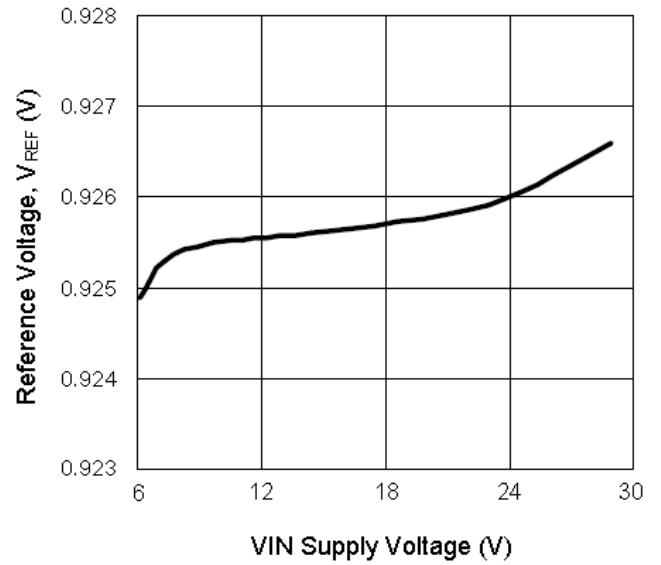

**Switching Frequency vs. Junction Temperature**

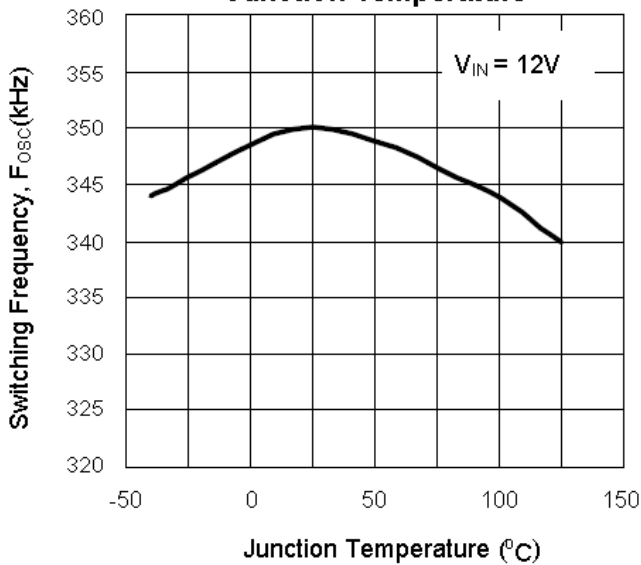

**Switching Frequency vs. VIN Supply Voltage**

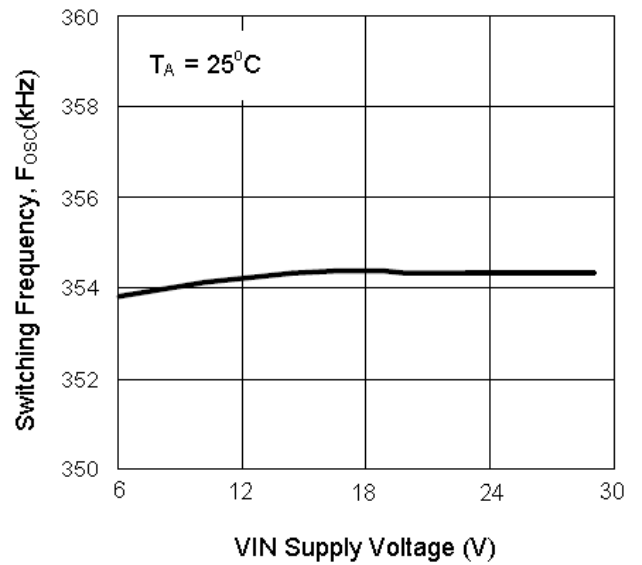



Reference Voltage vs. Junction Temperature

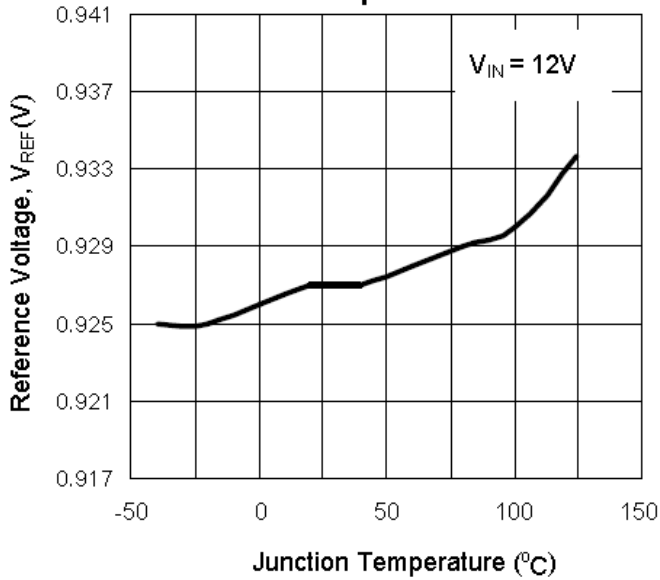

Enable

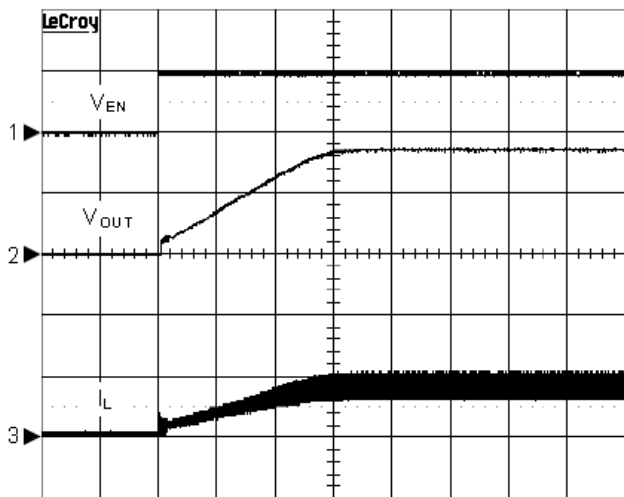

V<sub>IN</sub> = 12V, V<sub>OUT</sub> = 3.3V, C<sub>OUT</sub> = 22uF, L = 10uH, R<sub>LOAD</sub> = 2Ω

CH1: V<sub>EN</sub>, 5V/Div, DC  
 CH2: V<sub>OUT</sub>, 2V/Div, DC  
 CH3: I<sub>L</sub>, 2A/Div, DC  
 TIME: 5ms/Div

Shutdown

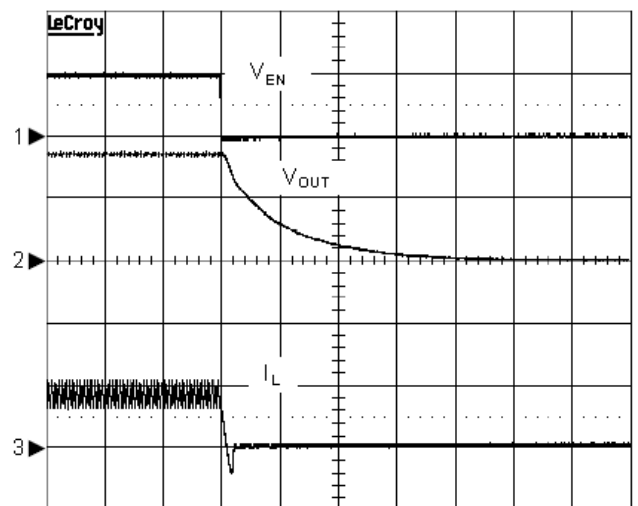

V<sub>IN</sub> = 12V, V<sub>OUT</sub> = 3.3V, C<sub>OUT</sub> = 22uF, L = 10uH, R<sub>LOAD</sub> = 2Ω

CH1: V<sub>EN</sub>, 5V/Div, DC  
 CH2: V<sub>OUT</sub>, 2V/Div, DC  
 CH3: I<sub>L</sub>, 2A/Div, DC  
 TIME: 50μs/Div

### Current Limit & Frequency Foldback

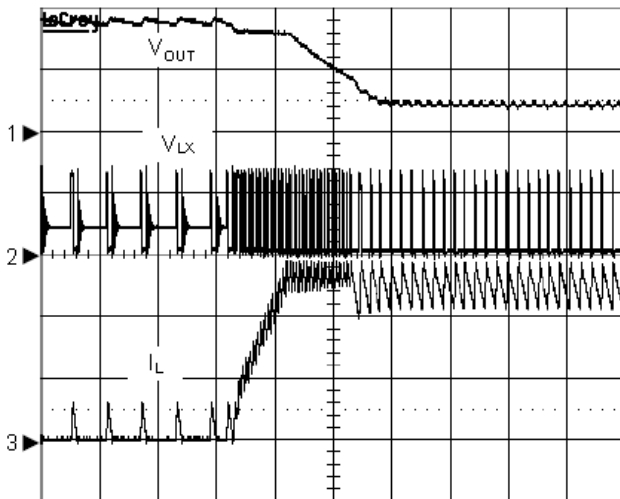

$V_{IN}=12V$ ,  $V_{OUT}=3.3V$ ,  $C_{OUT}=22\mu F$ ,  $L=10\mu H$ ,  
Ramp up  $I_{OUT}$  into current limit

CH1:  $V_{EN}$ , 5V/Div, DC  
CH2:  $V_{LX}$ , 10V/Div, DC  
CH3:  $I_L$ , 2A/Div, DC

TIME: 50µs/Div

### Normal Operation in Heavy Load

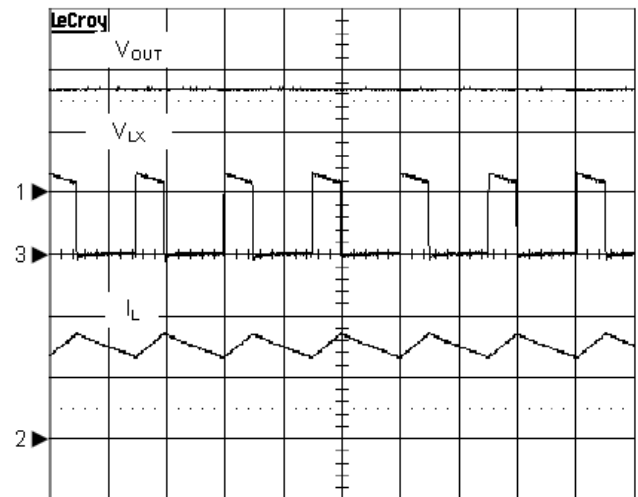

$V_{IN}=12V$ ,  $V_{OUT}=3.3V$ ,  $C_{OUT}=22\mu F$ ,  $L=10\mu H$ ,  
 $I_{OUT}=3A$

CH1:  $V_{OUT}$ , 2V/Div, DC  
CH2:  $I_L$ , 2A/Div, DC  
CH3:  $V_{LX}$ , 10V/Div, DC

TIME: 2µs/Div

### Power On

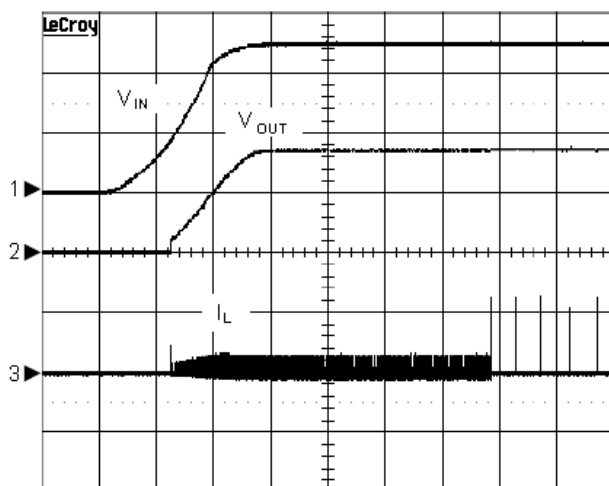

$V_{IN}=12V$ ,  $V_{OUT}=3.3V$ ,  $C_{OUT}=22\mu F$ ,  $L=10\mu H$ , no  
load

CH1:  $V_{IN}$ , 5V/Div, DC  
CH2:  $V_{OUT}$ , 2V/Div, DC  
CH3:  $I_L$ , 0.5A/Div, DC

TIME: 10ms/Div

### Power Off

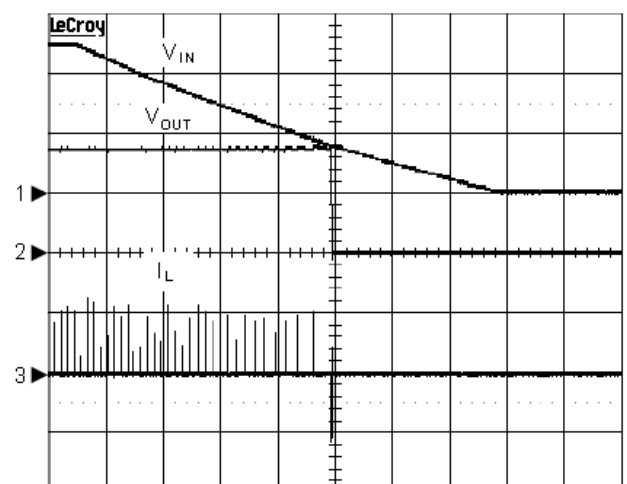

$V_{IN}=12V$ ,  $V_{OUT}=3.3V$ ,  $C_{OUT}=22\mu F$ ,  $L=10\mu H$ , no  
load

CH1:  $V_{IN}$ , 5V/Div, DC  
CH2:  $V_{OUT}$ , 2V/Div, DC  
CH3:  $I_L$ , 0.5A/Div, DC

TIME: 50ms/Div

Normal Operation in Light Load

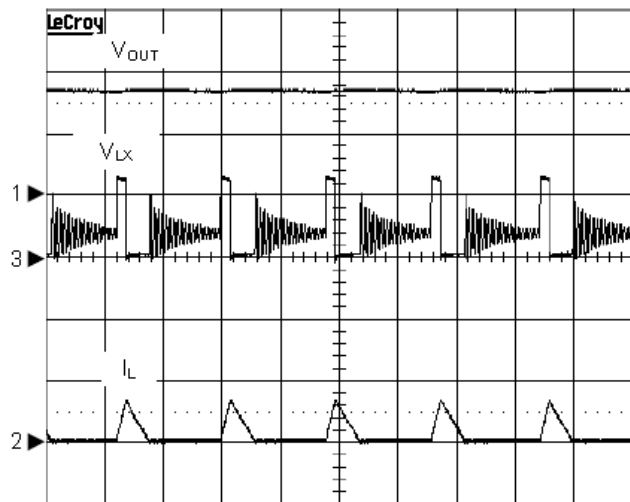

$V_{IN}=12V$ ,  $V_{OUT}=3.3V$ ,  $C_{OUT}=22\mu F$ ,  $L=10\mu H$ ,  
 $I_{OUT}=100mA$

CH1:  $V_{OUT}$ , 2V/Div, DC

CH2:  $I_L$ , 1A/Div, DC

CH3:  $V_{LX}$ , 10V/Div, DC

TIME: 5 $\mu s$ /Div

Load Transient

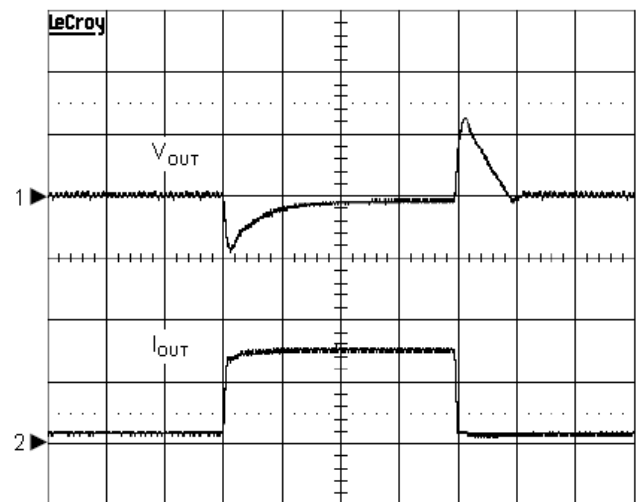

$V_{IN}=12V$ ,  $V_{OUT}=3.3V$ ,  $C_{OUT}=22\mu F$ ,  $L=10\mu H$ ,  
 $COMP=6.8k\Omega+3.9nF$ ,  $I_{OUT}=300mA-3A-300mA$

CH1:  $V_{OUT}$ , 0.5V/Div, offset=3.3V

CH2:  $I_{OUT}$ , 2A/Div, DC

TIME: 50 $\mu s$ /Div

Load Transient

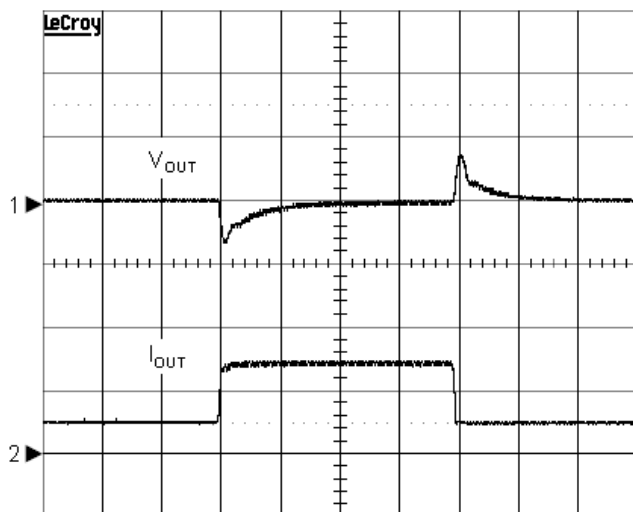

$V_{IN}=12V$ ,  $V_{OUT}=3.3V$ ,  $C_{OUT}=22\mu F$ ,  $L=10\mu H$ ,  
 $COMP=6.8k\Omega+3.9nF$ ,  $I_{OUT}=1A-3A-1A$

CH1:  $V_{OUT}$ , 0.5V/Div, offset=3.3V

CH2:  $I_{OUT}$ , 2A/Div, DC

TIME: 50 $\mu s$ /Div

Short Circuit

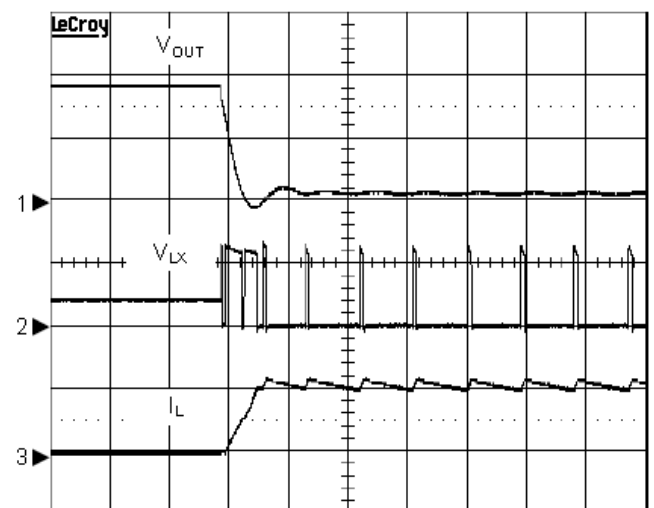

$V_{IN}=12V$ ,  $V_{OUT}=3.3V$ ,  $C_{OUT}=22\mu F$ ,  $L=10\mu H$ ,  
 $V_{OUT}$  short to ground

CH1:  $V_{OUT}$ , 2V/Div, DC

CH2:  $V_{LX}$ , 10V/Div, DC

CH3:  $I_L$ , 5A/Div, DC

TIME: 10 $\mu s$ /Div

## Function Description

### Main Control Loop

The TD2786 is a constant frequency current mode switching regulator. During normal operation, the internal N-channel power MOSFET is turned on each cycle when the oscillator sets an internal RS latch and would be turned off when an internal current comparator (ICMP) resets the latch. The peak inductor current at which ICMP resets the RS latch is controlled by the voltage on the COMP pin, which is the output of the error amplifier (EAMP). An external resistive divider connected between VOUT and ground allows the EAMP to receive an output feedback voltage  $V_{FB}$  at FB pin. When the load current increases, it causes a slight decrease in  $V_{FB}$  relative to the 0.92V reference, which in turn causes the COMP voltage to increase until the average inductor current matches the new load current.

### VIN Power-On-Reset (POR) and EN

#### Under-voltage Lockout

The TD2786 keep monitoring the voltage on VIN pin to prevent wrong logic operations which may occur when VIN voltage is not high enough for the internal control circuitry to operate. The VIN POR has a rising threshold of 4.1V (typical) with 0.5V of hysteresis.

An external under-voltage lockout (UVLO) is sensed at the EN pin. The EN UVLO has a rising threshold of 2.5V with 0.2V of hysteresis. The EN pin should be connected a resistor divider from VIN to EN.

After the VIN and EN voltages exceed their respective voltage thresholds, the IC starts a start-up process and then ramps up the output voltage to the setting of output voltage

#### Over-Temperature Protection (OTP)

The over-temperature circuit limits the junction temperature of the TD2786. When the junction temperature exceeds  $T_J=+160^{\circ}\text{C}$ , a thermal sensor turns off the power MOSFET, allowing the devices to cool. The thermal sensor allows the converter to start a start-up process and regulate

the output voltage again after the junction temperature cools by  $50^{\circ}\text{C}$ .

The OTP is designed with a  $50^{\circ}\text{C}$  hysteresis to lower the average  $T_J$  during continuous thermal overload conditions, increasing lifetime of the IC.

### Enable / Shutdown

Driving EN to ground places the TD2786 in shutdown. When in shutdown, the internal power MOSFET turns off, all internal circuitry shuts down

### Current-Limit Protection

The TD2786 monitors the output current, flowing through the N-Channel power MOSFET, and limits the IC from damages during overload, short-circuit and over voltage conditions.

### Frequency Foldback

The foldback frequency is controlled by the FB voltage. When the FB pin voltage is under 0.6V, the frequency of the oscillator will be reduced to 110kHz. This lower frequency allows the inductor current to safely discharge, thereby preventing current runaway. The oscillator's frequency will switch to its designed rate when the feedback voltage on FB rises above the rising frequency foldback threshold (0.6V, typical) again

### Over-Voltage Protection

The over-voltage function monitors the output voltage by FB pin. When the FB voltage increases over 120% of the reference voltage, the over-voltage protection comparator will force the low-side MOSFET gate driver high. This action actively pulls down the output voltage. As soon as the output voltage is within regulation, the OVP comparator is disengaged. The chip will restore its normal operation.

## Application Information

### Setting Output Voltage

The regulated output voltage is determined by:

$$V_{OUT} = 0.925 \times \left(1 + \frac{R_1}{R_2}\right)$$

To prevent stray pickup, please locate resistors R1 and R2 close to TD2786.

### Inductor Capacitor Selection

Use small ceramic capacitors for high frequency decoupling and bulk capacitors to supply the surge current needed each time the N-channel power MOSFET (Q1) turns on. Place the small ceramic capacitors physically close to the VIN and between the VIN and GND.

The important parameters for the bulk input capacitor are the voltage rating and the RMS current rating. For reliable operation, select the bulk capacitor with voltage and current ratings above the maximum input voltage and largest RMS current required by the circuit. The capacitor voltage rating should be at least 1.25 times greater than the maximum input voltage and a voltage rating of 1.5 times is a conservative guideline. The RMS current (IRMS) of the bulk input capacitor is calculated as the following equation:

$$I_{RMS} = I_{OUT} \sqrt{D \times (1 - D)}$$

where D is the duty cycle of the power MOSFET.

For a through hole design, several electrolytic capacitors maybe needed. For surface mount designs, solid tantalum capacitors can be used, but caution must be exercised with regard to the capacitor surge current rating.

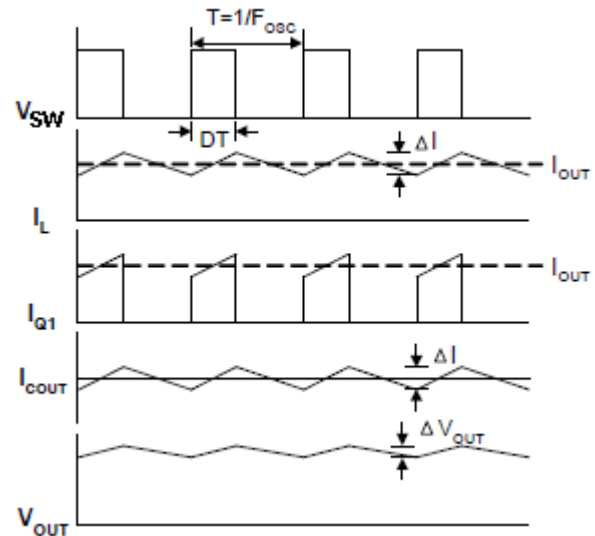
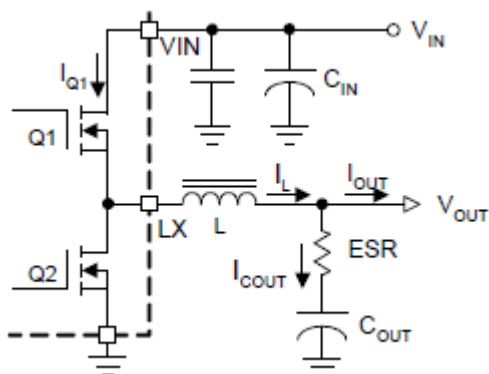

### Output Capacitor Selection

An output capacitor is required to filter the output and supply the load transient current. The filtering requirements are the function of the switching frequency and the ripple current (DI). The output ripple is the sum of the voltages, having phase shift, across the ESR and the ideal output capacitor. The peak-to-peak voltage of the ESR is calculated as the following equations:

$$D = \frac{V_{OUT}}{V_{IN}}$$

$$\Delta I = \frac{V_{OUT} \times (1 + D)}{F_{OSC} \times L}$$

$$V_{ESR} = \Delta I \times ESR$$

The peak- to-peak voltage of the ideal output capacitor is calculated as the following equations:

$$\Delta V_{COUT} = \frac{\Delta I}{8 \times F_{OSC} \times C_{OUT}}$$

For the applications using bulk capacitors, the V<sub>COUT</sub> is much smaller than the V<sub>ESR</sub> and can be ignored. Therefore the AC peak-to-peak output voltage (ΔV<sub>OUT</sub>) is shown below:

$$\Delta V_{OUT} = \Delta I \times ESR$$

For the applications using bulk capacitors, the V<sub>ESR</sub> is much smaller than the ΔV<sub>COUT</sub> and can be ignored. Therefore, the AC peak-to-peak output voltage( ΔV<sub>OUT</sub>) is to ΔV<sub>COUT</sub>

### Output Capacitor Selection

The load transient requirements are the function of the slew rate (di/dt) and the magnitude of the transient load current. These requirements are generally met with a mix of capacitors and careful layout. High frequency capacitors initially supply the transient and slow the current load rate seen by the bulk capacitors. The bulk filter capacitor values are generally determined by the ESR and voltage rating requirements rather than actual capacitance requirements.

High frequency decoupling capacitors should be placed as close to the power pins of the load as physically possible. Be careful not to add inductance in the circuit board wiring that could cancel the usefulness of these low inductance components. An aluminum electrolytic capacitor’s ESR value is related to the case size with lower ESR available in larger case sizes. However, the Equivalent Series Inductance (ESL) of these capacitors increases with case size and can reduce the usefulness of the capacitor to high slew-rate transient loading.

Table1 Capacitor Selection Guide

Vender	Model	Capacitance (µF)	TC	Voltage Rating(V)	Si2e
muRata	GRM31CR61E106K	10	X5R	25	1206
muRata	GRM31CR61C226K	22	X5R	16	1206

### Inductor Value Calculation

The operating frequency and inductor selection are interrelated in that higher operating frequencies permit the use of a smaller inductor for the same amount of inductor ripple current. However, this is at the expense of efficiency due to an increase in MOSFET gate charge losses. The equation shows that the inductance value has a direct effect on ripple current.

Accepting larger values of ripple current allows the use of low inductances, but results in higher output voltage ripple and greater core losses. A reasonable starting point for setting ripple current is  $\Delta I \leq 0.4 \times I_{OUT(max)}$ . Please be noticed that the maximum ripple current occurs at the maximum input voltage. The minimum inductance of the inductor is calculated by using the following equation:

$$\frac{V_{OUT} \times (V_{IN} - V_{OUT})}{340000 \times L \times V_{IN}} \leq 1.2$$

$$L \geq \frac{V_{OUT} \times (V_{IN} - V_{OUT})}{408000 \times V_{IN}}$$

Where  $V_{IN} = V_{IN(MAX)}$

Table2 Inductor Selection Guide

Vender	Model	Inductance (µH)	DCR (mΩ)	Current Rating(A)
CYNTEC	PCMB063T-100MS	10	62	4
Gausstek	PL94P051M-15U	15	50	3
Gausstek	PL94P051M-10U	10	38	3.8

Package Information

SOP-8 Package Outline Dimensions

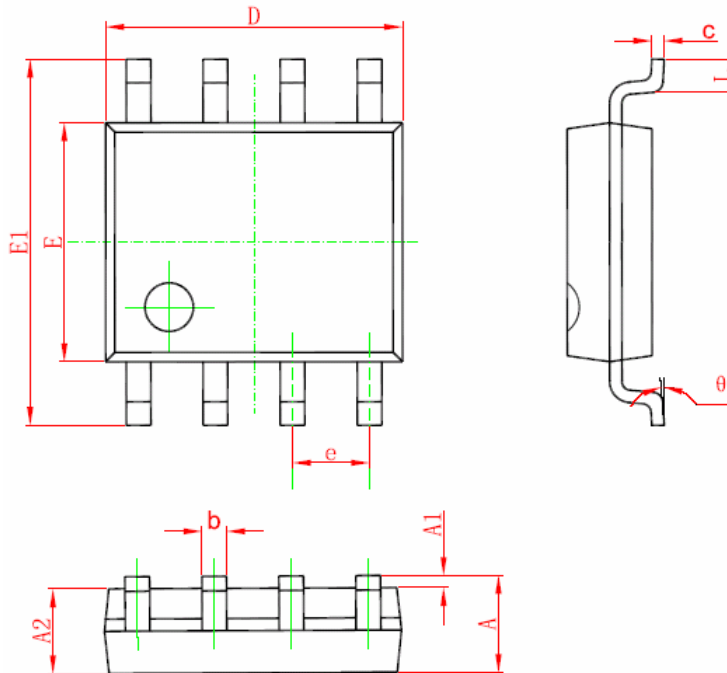

Symbol	Dimensions In Millimeters		Dimensions In Inches	
	Min	Max	Min	Max
A	1.350	1.750	0.053	0.069
A1	0.100	0.250	0.004	0.010
A2	1.350	1.550	0.053	0.061
b	0.330	0.510	0.013	0.020
c	0.170	0.250	0.006	0.010
D	4.700	5.100	0.185	0.200
E	3.800	4.000	0.150	0.157
E1	5.800	6.200	0.228	0.244
e	1.270 (BSC)		0.050 (BSC)	
L	0.400	1.270	0.016	0.050
θ	0°	8°	0°	8°

Design Notes